



---

MULTIDUTY®

---

Automatic Self-Cleaning  
Viscous Air Filter

---

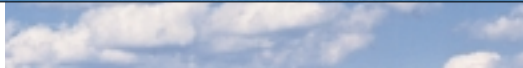
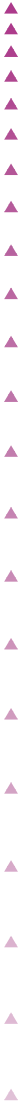

---

B E T T E R   A I R   I S   O U R   B U S I N E S S ®

---



# MultiDuty Automatic Self-Cleaning Viscous Air Filter

The MultiDuty is an automatic self-cleaning viscous air filter using a rotating curtain of metal panels as the filtering media, requiring little maintenance.

## APPLICATION

- Air filtration for areas with high dust concentrations such as Steel-, Chemical- and Cement plants.
- Pre filtration of air for multistage air filtration in ventilation systems with high capacities
- Intake filters for gasturbines, compressors and Diesel engines.

## PRINCIPLE OF OPERATION

The filtering curtain is composed of overlapping panels, type DD, which cover each other in such a way that the air has to change four times direction in the inlet- and as well in the outlet curtain.

The panels are die-stamped from sheet metal with knurled louvres turned at an angle in the direction of the airflow. The filtering is obtained by a film of Viscosine on the panels that retains all dust particles that will touch them. The panels are mounted on both sides to an endless chain that will be moved a few centimeters, controlled by a timer at 15 minutes intervals, in order to make one complete turn in 24 hours.

The curtains at the inlet and outlet form two masses in equilibrium on the upper shaft, due to this fact, the required power of the electric motor is very low. The power consumption of the MultiDuty is therefore low.

The filtering surface will be renewed after the panels in the rear curtain have passed the outlet opening. When the panels enter the reservoir at the base of the filter, they separate and hang widely spaced for ease of cleaning as they pass through the Viscosine bath. The dust will be washed off and will deposit on the bottom of the reservoir.

## CONSTRUCTION

The MultiDuty is constructed in steel plate for industrial application and consists of the following elements:

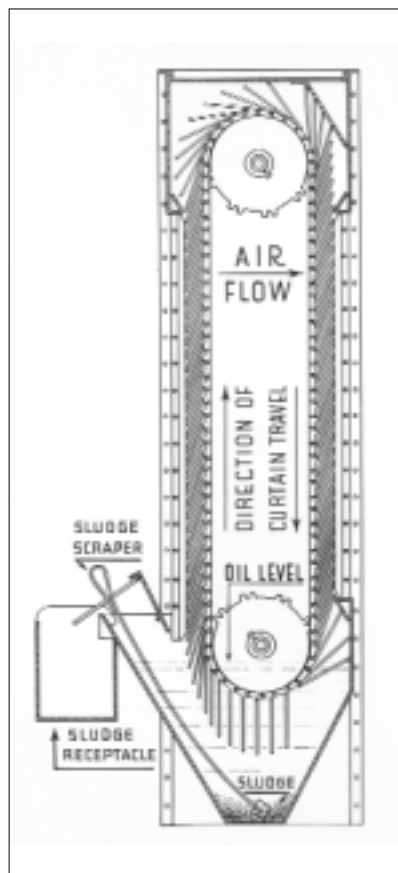

- A rigid metallic frame consisting of a top assembly a base reservoir and two side panels
- A filter curtain consisting of metal panels which are supported and moved on each side by a chain
- The base reservoir containing the Viscosine for impregnation of the panels
- An electric motor of 0,18 kW with reducer which rotates the top shaft through a ratchet wheel
- A controlbox IP55 containing the timer and the terminals

The MultiDuty is available in standard sections with widths of 914, 1219, 1524 and 1829 mm.

The height of all sections ranges from 1526 up to 5488 mm, with increments of 100 mm.

## VISCOSINE

AAF's Viscosine has the following advantages:

- Capillary action of the highly viscous adhesives enables it to cling to the panels and thoroughly saturate each dust particle
- Accumulated dust will not break away and blow downstream
- Maintains its dust trapping characteristics over an extended time scale
- Non toxic and odourless

Some Viscosine will be lost each time the sludge is removed. It is recommended to keep the proper level. Average annual usage is approximately 10%.

Types of Viscosine:

- Viscosine BA for temperatures up to 35°C
- Viscosine MA for higher temperatures up to 55°C

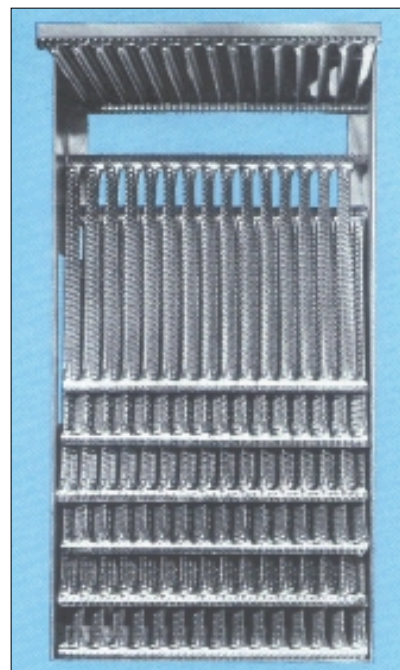

*Overlapping panels, type DD*

## Standard Arrangements

### OPTIONS

- Intake Protection
  - Weather Louvres with trash screen
  - Horizontal Louvres in galvanized steel
  - Vertical Louvres in PP
- Plenum Chamber
  - Plenum Chamber bolted to the outlet of the MultiDuty equipped with a perforated baffle plate for even air distribution over the entire filter face and a connection flange.
- Cold Weather Protection
  - Electric heater to be installed in the Viscosine reservoir, to be used when the air temperature in the filter is below 5°C

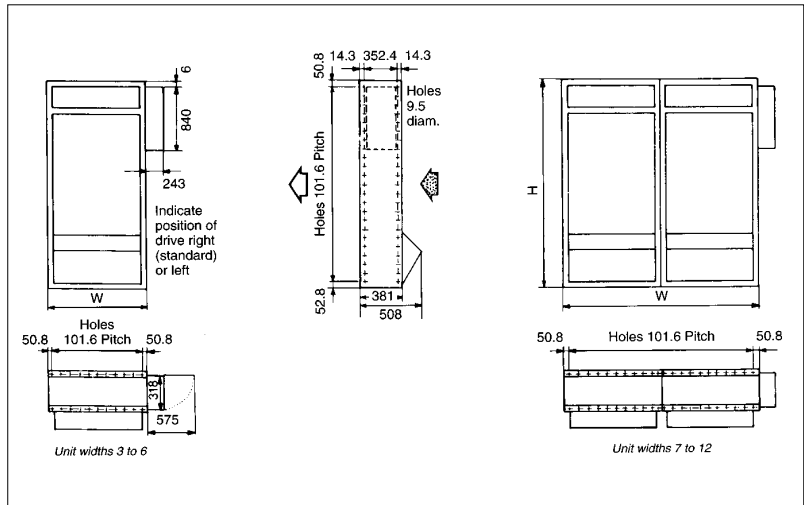

Single end drive for a MultiDuty with 1 or 2 sections

### PERFORMANCE DATA

#### Dust Arrestance

ASHRAE test	: 77%
Using Arizona Road Dust fine	: 82%
EN 779 Class	: G2/G3

#### Average Operating Resistance

At 2.5 m/s	: 200 Pa
At 2.0 m/s	: 130 Pa

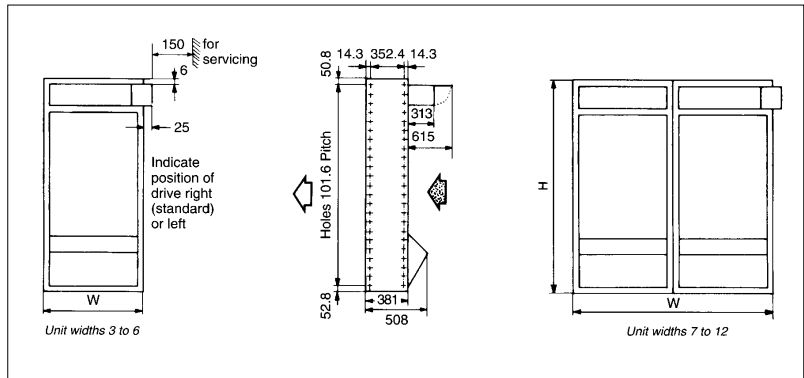

Single front drive for a MultiDuty with 1 or 2 sections

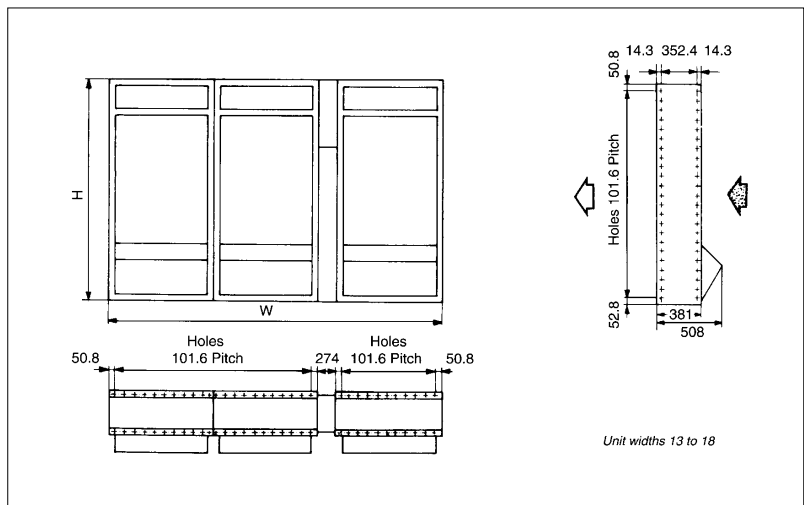

Intermediate drive for a MultiDuty with 3 or 4 sections

# Standard & Approximate Transport Weights

## Approximate Weights

Weights are given for each section No. (in kg). To calculate the total weight, add 75 kg for each drive unit.

Height Designation	Section No.			
No.	3	4	5	6
54	310	385	460	705
58	320	395	475	730
60	330	410	490	755
64	340	425	505	775
68	350	440	520	795
70	365	450	530	815
74	375	460	545	835
78	385	470	560	860
80	395	485	575	880
84	405	495	590	900
88	415	505	605	925
90	425	520	615	945
94	435	535	630	965

Height Designation	Section No.			
No.	3	4	5	6
98	450	550	645	985
100	460	560	660	1000
104	470	575	675	1025
108	480	590	690	1050
110	490	600	700	1070
114	500	610	715	1090
118	510	620	730	1110
120	520	630	740	1130
124	530	645	755	1150
128	540	660	770	1175
130	550	670	785	1195
134	560	680	800	1215
138	575	695	815	1240

Height Designation	Section No.			
No.	3	4	5	6
140	585	705	825	1260
144	590	715	840	1280
148	610	730	855	1300
150	615	740	865	1320
154	625	750	880	1340
158	640	765	895	1360
160	650	775	910	1380
164	660	790	925	1400
168	670	805	940	1420
170	680	815	950	1440
174	690	825	965	1460
178	705	840	980	1480
180	715	850	995	1500

**AAF-International B.V.**  
**P.O. Box 7928**  
**1008 AC Amsterdam**  
**The Netherlands**  
**Tel.: + 31 20 549 44 11**  
**Fax: + 31 20 644 43 98**

### International AAF Offices

<b>Austria</b>	AAF-Luftreinigungssysteme Gesellschaft m.b.H., Weyrgasse 8/7, A-1030 Vienna Tel.: + 43 1 712 59 11, Fax: + 43 1 712 59 111
<b>Belgium</b>	AAF-S.A., Avenue Louise 149, B 1050 Brussels Tel.: + 32 2 426 54 51, Fax: + 32 2 426 74 15
<b>Canada</b>	AAF-Canada, 225 Guthrie Street, Dorval, Quebec, H9P 2P5 Tel.: + 1 514 631 10 36, Fax: + 1 514 633 64 50
<b>France</b>	AAF-S.A., Division Filtration, 42, Rue Fortuny, 75017 Paris Tel.: + 33 1 44 29 93 30, Fax: + 33 1 42 67 26 66
<b>Germany</b>	AAF-Lufttechnik GmbH, P.O. Box 130618, 44316 Dortmund Tel.: + 49 231 921033-0, Fax: + 49 231 921033-23
<b>Great Britain</b>	AAF-Ltd., Bassington Lane, Cramlington, Northumberland NE23 8AF Tel.: + 44 1670 71 34 77, Fax: + 44 1670 59 02 62
<b>Greece</b>	AAF-Environmental Control Epe, 2 Papada street, 11525 Athens Tel.: + 30 1 692 35 78, Fax: + 30 1 691 16 50
<b>Italy</b>	AAF-S.r.l., Via Valassina 24, 20159 Milan Tel.: + 39 2 607 02 51 r.a., Fax: + 39 2 607 02 55, Telex: 332433 amfilt
<b>Middle East</b>	AAF-International B.V., P.O. Box 7928, 1008 AC Amsterdam Tel.: + 31 20 549 44 11, Fax: + 31 20 644 43 98, Telex 12372 amfi nl
<b>Netherlands</b>	AAF-International B.V., P.O. Box 7928, 1008 AC Amsterdam Tel.: + 31 20 549 44 11, Fax: + 31 20 644 43 98
<b>Saudi Arabia</b>	AAF Saudi Arabia Ltd., P.O. Box 59336, Riyadh 11525 Tel.: + 966 1 265 1116, Fax: + 966 1 265 0005
<b>Singapore</b>	AAF Asia Pte Ltd., 8 Gul Circle, Singapore 2262 Tel.: + 65 861 36 96, Fax: + 65 861 10 91, Telex: RS 26953 amfil
<b>Spain</b>	AAF-S.A., C/Urartea, 11, P. Industrial Ali-Gobeo, 01010 Vitoria Tel.: + 34 45 24 18 00, Fax: + 34 45 24 80 86, Telex 65235436
<b>Turkey</b>	AAF Hava Filtreleri ve Ticaret A.S., Esentepe Cad., Bildircin Sok, No. 8, 80300 Mecidiyekoy-Istanbul, Tel.: + 90 212 211 32 33, Fax: + 90 212 273 19 30
<b>USA</b>	American Air Filter, 10300 Ormsby Pak Place, Suite 600, P.O. Box 35690, Louisville, KY 40223-40232, Tel.: + 1 502 637 00 11, Fax: + 1 502 637 05 20

**AAF-S.A.**  
**Siège Social**  
**Rue William Dian**  
**BP 3**  
**27620 Gasny, France**  
**Tel.: + 33 2 32 53 60 60**  
**Fax: + 33 3 32 53 60 69**

### AAF Agents

#### Denmark

I.F. Luftfilter AS  
 Avedøreholmen 88  
 DK - 2650 Hvidovre  
 Tel.: + 45 36 49 66 00, Fax: + 45 36 77 10 07

#### Finland

Oy Dimitron Ab  
 Kutomotie 6 B  
 Tel.: + 358 9 270 700 10, Fax: + 358 9 224 310 20

#### Norway

AFF  
 Hogdaveien 4, 1540 Vestby  
 Tel.: + 47 64 95 55 44, Fax: + 47 64 95 55 43

#### Republic of South Africa

Gosair Filter Systems (PTY) Ltd.  
 6 Neutron Street, Chloorkop: Kempton Park  
 Tel.: + 27 11 393 19 24, Fax: + 27 11 393 10 17

#### Sweden

Mondial Filter  
 Tvinnargatan 29  
 50730 Bråmhult  
 Tel.: + 46 33 22 52 80, Fax: + 46 33 22 52 89



AAF has a policy of continuous product research and improvement and reserves the right to change design and specifications without notice.